

PROPER USAGE AND INSTALLATION FOR CHAMPION MODULAR SERIES DRAWERS IN SHELVING

The following instructions will provide you with a guide for installation and usage for the Modular Series drawers in Western Pacific Storage Shelving units. If at any time you need guidance or help, please do not hesitate to call us. Thanks again for choosing Champion Tool Storage.

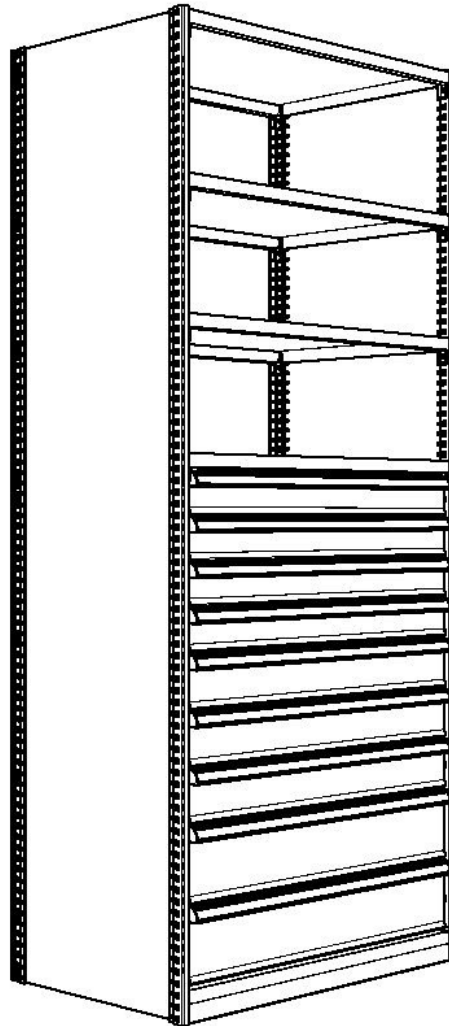

QUESTIONS

Champion Tool Storage

3070 Lower Mill Dr.

Hood River Oregon 97031

W: www.championbuilt.com

E-mail: info@championbuilt.com

Phone: 866-391-4200

8 AM - 5PM, PST, Monday-Friday

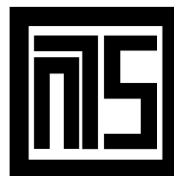

MODULAR SERIES

Installation

1.

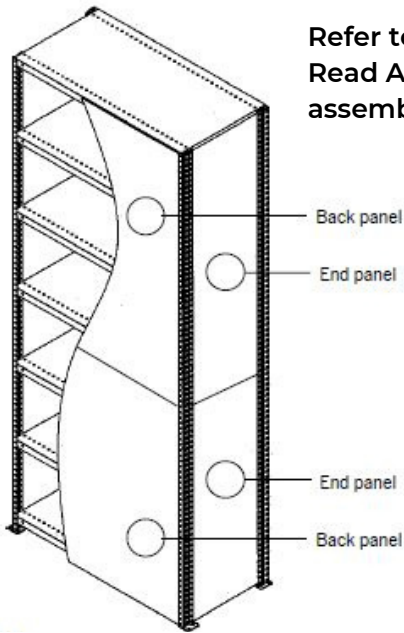

Refer to the shelving manufacturer's assembly instructions. Read Assembly Instructions thoroughly before beginning assembly.

2.

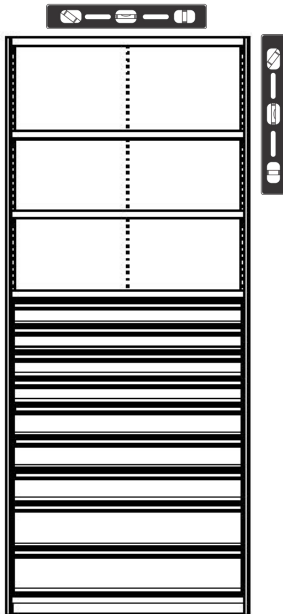

Shelving unit must be anchored to the floor and level before drawer installation. Refer to shelving manufacturer anchoring instructions.

Installation

3.

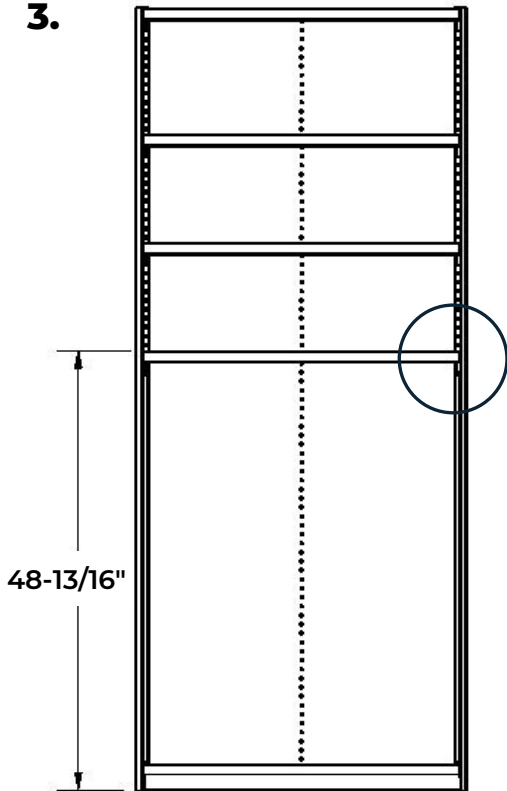

After the housing is assembled, install the first shelf at 48-13/16" from the floor to the top of the shelf. Use the shelving suppliers clip or mount to install shelf. This applies to 48", 36", and 24" drawer sections. All other shelves to be installed as needed. Install drawer mount adaptors as shown below. Be sure to install mounts directly below shelf mount as shown in Fig. 1. See Fig. 2 for location and part number details.

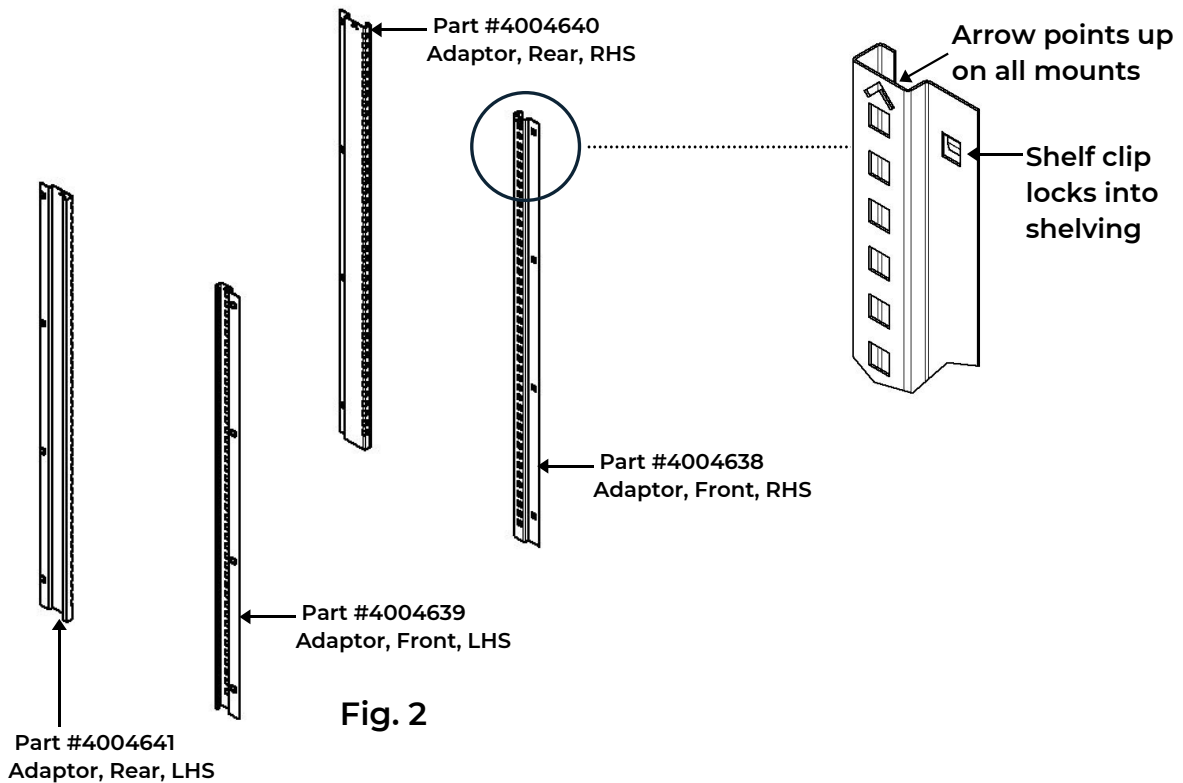
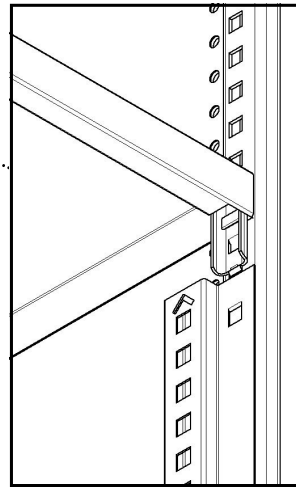

Installation

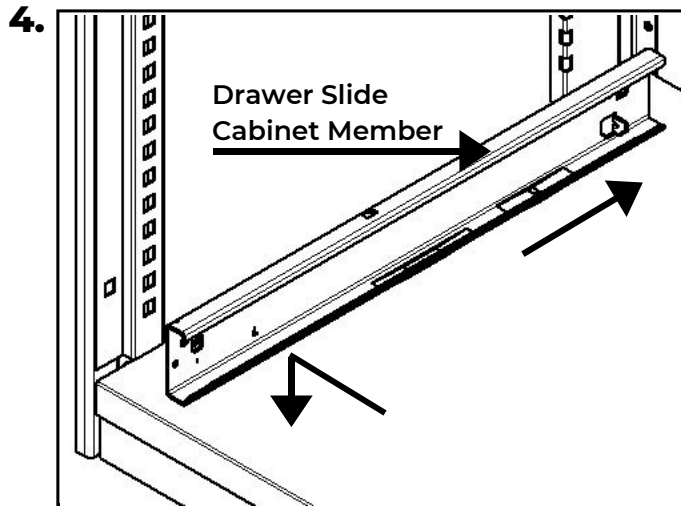

To install drawers, start with the Cabinet Member. Please note the cabinet members are marked LH and RH. Install in the lowest position available on the Adaptors using the clip on the cabinet member. Start by inserting the rear clip into the rear adapter, then align the front clip and use a soft mallet to tap member into place. Repeat for opposite side. Now install the slide middle member into the cabinet member by rolling inside of the cabinet member., See Fig. 3.

Drawer Slide Middle Member

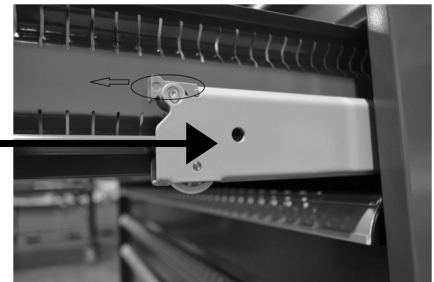
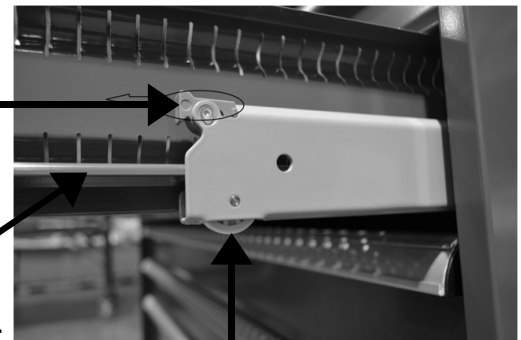

Fig. 3

5. Insert Drawer into drawer slides aligning the drawer member to ride on the middle member front wheel. As you roll the drawer into place, you will need to slightly lift the drawer over the stop. Continue to push drawer in. Once drawer is pushed in, secure the gray plastic clip by pushing in, see figure 4.

Drawer Member

Fig. 4



Front Wheel

6. To install remaining drawers, repeat process by installing the Cabinet Member as close to the top of the drawer below. See Fig. 5.

Drawer Slide Cabinet Member

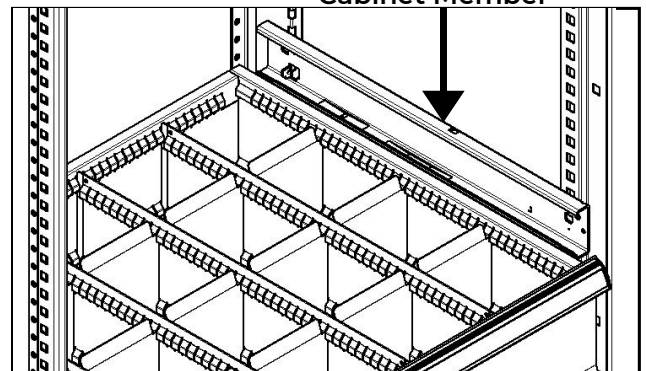
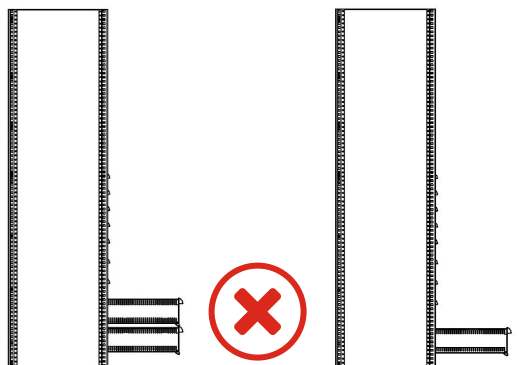
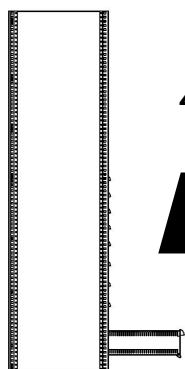

Fig. 5

Proper Use



Do not open more than one drawer at a time.



440lb
MAX

440lb Max load per
drawer, evenly
distributed

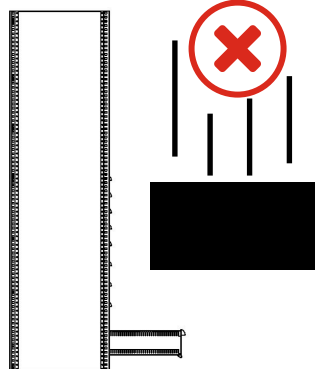

Do not drop
items into
drawers,
damage may
occur.



Do not use drawers as a step, or seat,
injury or damage may occur.

How to Load

STEP 1.

- Start by loading the bottom drawer first.
- Load the drawer from the back to the front of the drawer.

STEP 2.

- Load the second lowest drawer in the same manner as the first.
- Repeat until drawers are filled.

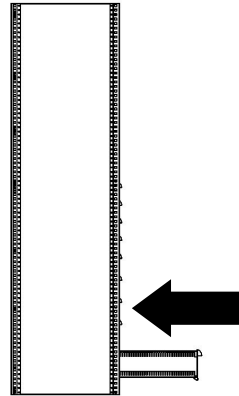

Proper Care

- Periodically clean the drawer fronts, drawer trim, and other surfaces with a mild detergent and water.

Safety Information

- Secure the product before use.
- Do not tow the product with power equipment.
- Do not alter this product in any manner. Doing so will void the warranty.
- Do not open more than one drawer at a time.



Do not attach or mount this product to a vehicle. This may cause personal injury or product damage. Mounting this product to a vehicle in any manner will void the warranty.



Do not stand or sit on this product. Doing so may cause personal injury.



Do not use drawers as steps or sit in drawer on this product. Doing so may cause personal injury.



This product must be on a level surface at all times. If stored or moved on an unlevel surface, personal injury or product damage may occur. If product is moved, lock all drawer before moving.

Warranty

Champion Tool Storage warrants only to the original purchaser that our Tool Storage products are free from defects in materials and workmanship for so long as the original purchaser retains ownership, possession and control of the product. Our Warranty only applies to Champion Tool Storage manufactured Professional Series, Modular Series, Flight line Series, and Military. Our warranty excludes damage caused by misuse, abuse, modifications to the unit, or the user not conforming to the recommended capacities as stated on our website or catalog. All hardware including drawer slides, hinges, and locks are warranted for one year from delivery date of the original invoice. If buyer claims that a product violates such warranty, Champion, upon notice promptly given, will either issue an RMA and shipping instructions for return to Champion at buyer's expense or provide transportation charges prepaid. Champion's sole obligation under its warranty shall be, at its option, to repair, replace or refund the price of any product thereof which is proved to violate such warranty. In no event shall Champion be liable to the buyer for special, indirect, incidental or consequential damages whatsoever including, without limitation, loss of profit or revenue. Title and risk of loss have passed to the original purchaser upon delivery to a common carrier. If any product is damaged in transit, the original purchaser must file a claim with the carrier, which claim is not a warranty claim. If you have any questions regarding your warranty please contact our sales department at 1-866-391-4200.