

# PROPER USE AND INSTALLATION FOR CHAMPION MODULAR SERIES FIXED DRAWER CABINETS

---

The following instructions will provide you with a guide for installation and usage for the Modular Series cabinets. If at any time you need guidance or help, please do not hesitate to call us. Thanks again for choosing Champion Tool Storage.

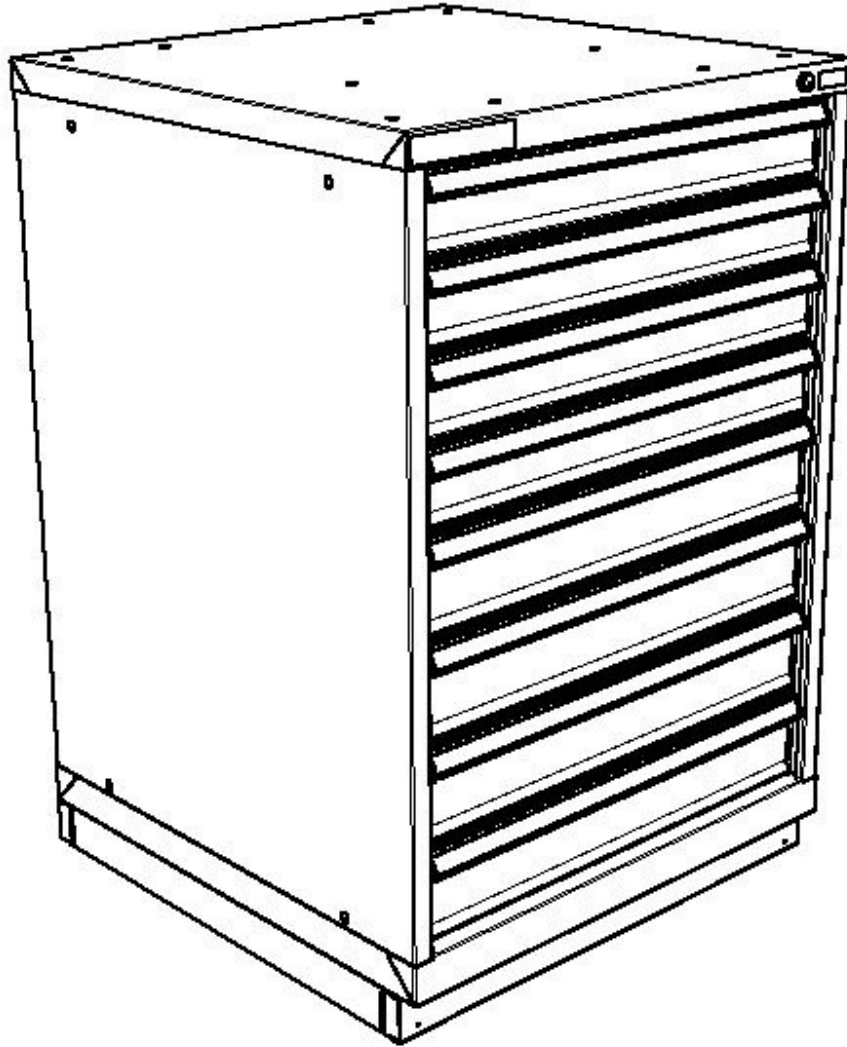

## QUESTIONS

### Champion Tool Storage

3070 Lower Mill Dr.

Hood River Oregon 97031

W: [www.championbuilt.com](http://www.championbuilt.com)

E-mail: [info@championbuilt.com](mailto:info@championbuilt.com)

Phone: 866-391-4200

8 AM - 5PM, PST, Monday-Friday

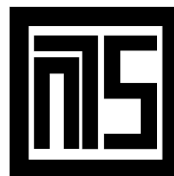

## MODULAR SERIES

# Installation

1.

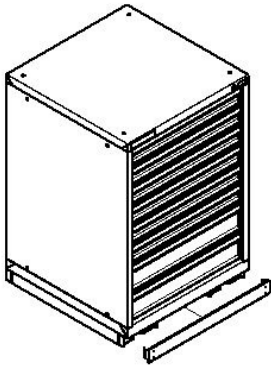

Use forklift or pallet jack to move and set cabinet in place. Cabinet must be locked while moving. If a base is supplied, remove front cover for access.



2.

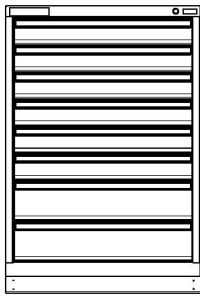

Fixed cabinets must be anchored to the floor. Install (2) 3/8" anchors into the floor using the layout in Fig.1. After anchors are installed, slide cabinet into the anchors and secure nut and washer to the cabinet with 9/16" deep socket. If you do not have a base, lower cabinet into place and secure cabinet to the anchor with 9/16" deep socket.

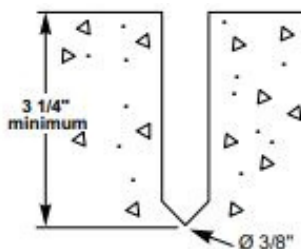
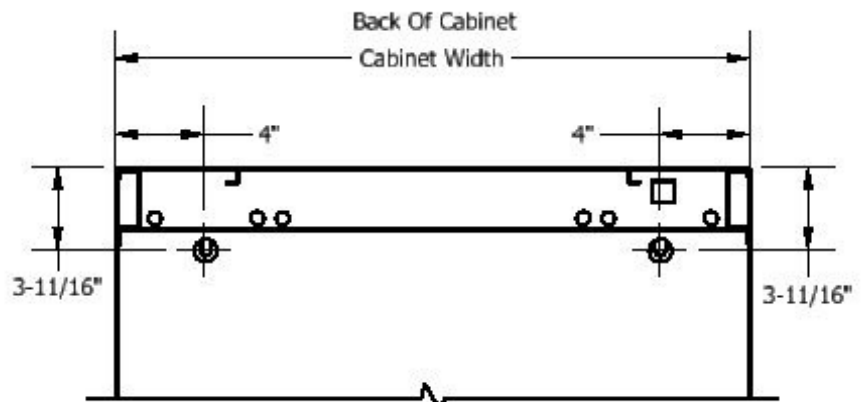
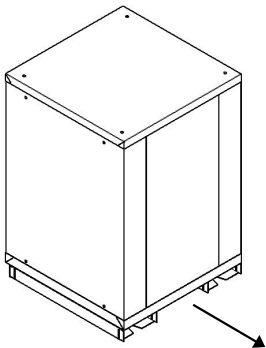

# Installation

3.

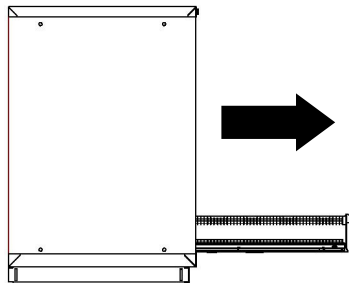

Remove drawers as need for access to secure concrete anchor to cabinet base. Note, unit must be in the unlocked position. To remove drawer, extend drawer to full extension. Pull gray lock out on middle slide member, see Fig. 2. Pull drawer out and lift over drawer slide stop as needed to remove. To remove more than one drawer, reach in and push the lock pawl in on the locking mechanism. This may require use of a rod to reach the unit, See Fig. 3 and Fig. 4. To install drawer, reverse removal step. Note when installing drawers, there is no need to reset the locking mechanism or alter the position of the pawls.

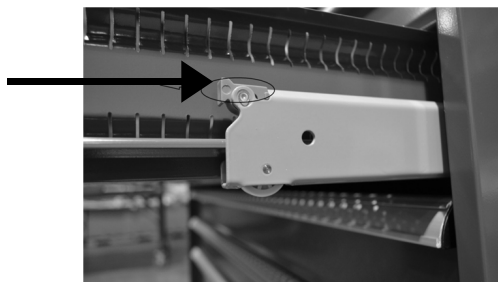

Fig. 2

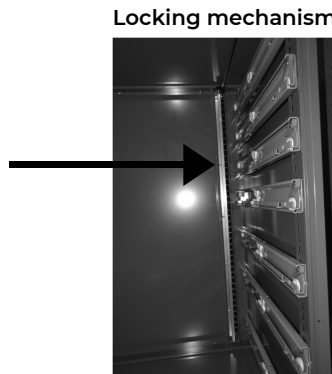

Fig. 3

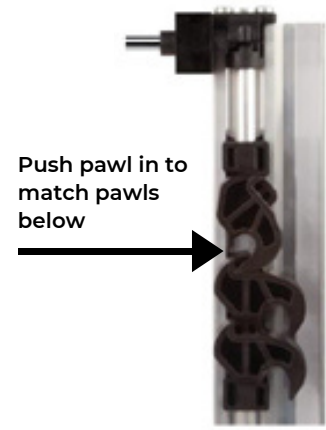
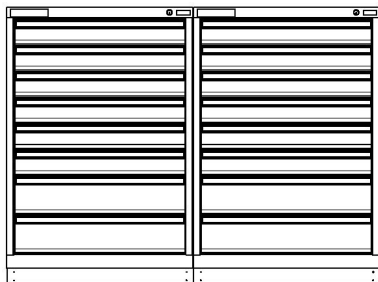

Fig. 4

4.



## Cabinet Ganging

Remove drawers, see step 3. Punch out the knockouts on the side of the cabinet using a punch and hammer, See Fig. 5. Align cabinets so that the front and top are flush. Use hardware shown in Fig. 6. Install all drawers.

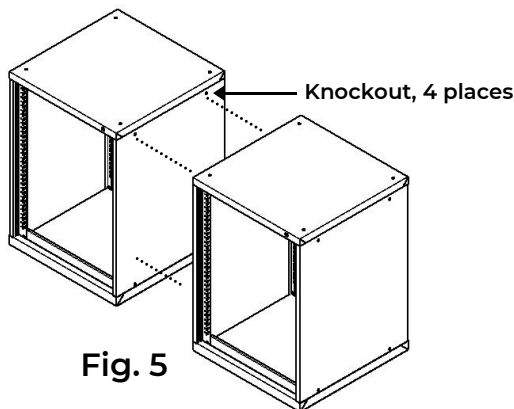
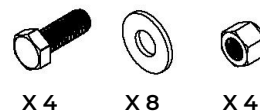

Fig. 5

## Ganging Hardware Kit Part #7001257



X 4

X 8

X 4

Fig. 6

# Installation

5.

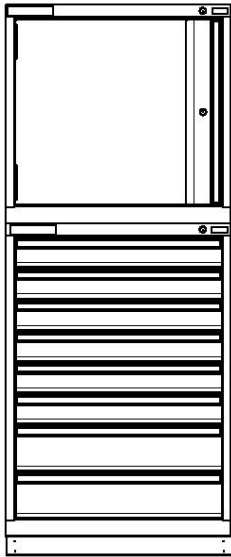

## Cabinet Stacking

Remove drawers, see step 3. Punch out the knockouts on the top and bottom of the cabinet using a punch and hammer, See Fig. 7. Align cabinets so that the front and top are flush. Use hardware shown in Fig. 6. Install all drawers.

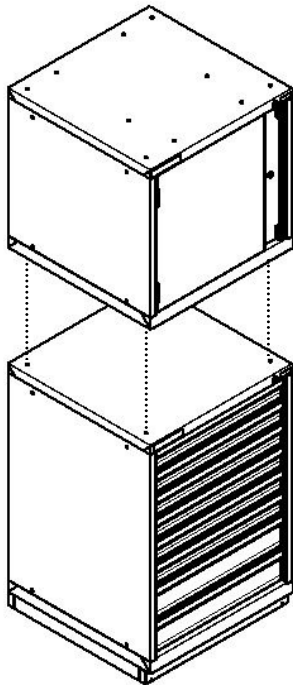

Fig. 7

Ganging Hardware Kit  
Part #7001257

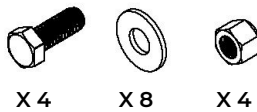
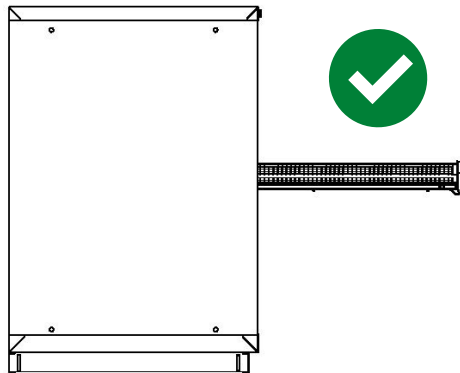
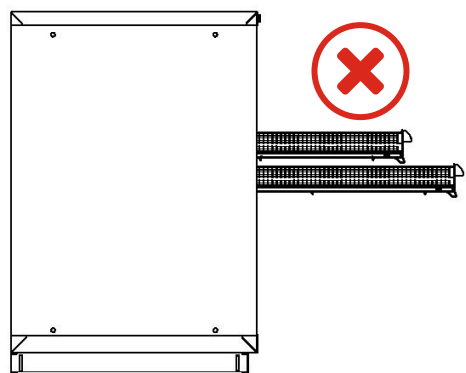
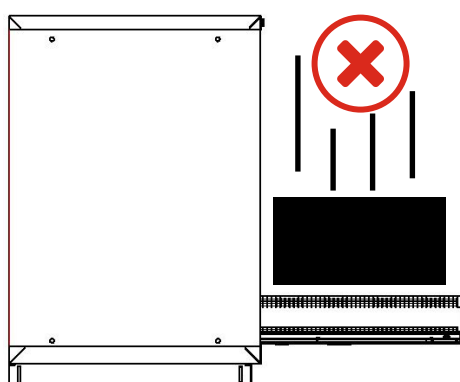
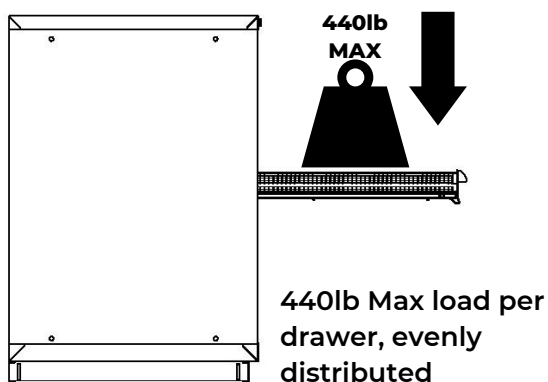

Fig. 6

## Proper Use



Do not try to open more than one drawer at a time. Your cabinet includes an anti tip locking device that only allows one drawer to open at a time. Forcing more than one drawer at a time may result in damage.



Do not drop items into drawers, damage may occur.

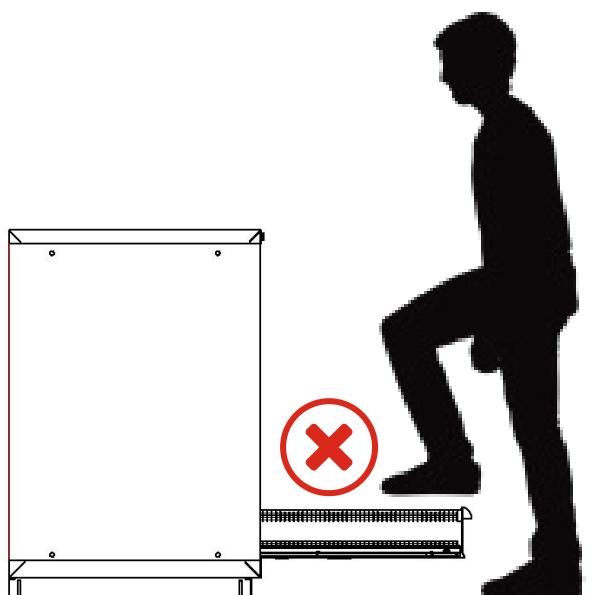

Do not use drawers as a step, or seat, injury or damage may occur.

## How to Load

### STEP 1.

- Start by loading the bottom drawer first.
- Load the drawer from the back to the front of the drawer.

### STEP 2.

- Load the second lowest drawer in the same manner as the first.
- Repeat until drawers are filled.

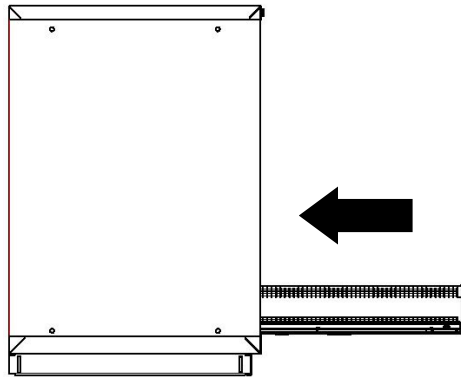

## Proper Care

- Periodically clean the drawer fronts, drawer trim, and other surfaces with a mild detergent and water.
- Auto wax preserves the storage unit's finish and protects against scratches. Apply the wax as you would on a car.

## Safety Information

- Secure the product before use.
- Do not tow the product with power equipment.
- Do not alter this product in any manner. Doing so will void the warranty.
- When locking unit, make sure all drawers or doors are in the fully closed position in order for the locking system to work properly.



Do not attach or mount this product to a vehicle. This may cause personal injury or product damage. Mounting this product to a vehicle in any manner will void the warranty.



Do not stand or sit on this product. Doing so may cause personal injury..



Do not use drawers as steps or sit in drawer on this product. Doing so may cause personal injury..



This product must be on a level surface at all times. If stored or moved on an unlevel surface, personal injury or product damage may occur. If product is moved, lock all drawer before moving.

## Warranty

Champion Tool Storage warrants only to the original purchaser that our Tool Storage products are free from defects in materials and workmanship for so long as the original purchaser retains ownership, possession and control of the product. Our Warranty only applies to Champion Tool Storage manufactured Professional Series, Modular Series, Flight line Series, and Military. Our warranty excludes damage caused by misuse, abuse, modifications to the unit, or the user not conforming to the recommended capacities as stated on our website or catalog. All hardware including drawer slides, hinges, and locks are warranted for one year from delivery date of the original invoice. If buyer claims that a product violates such warranty, Champion, upon notice promptly given, will either issue an RMA and shipping instructions for return to Champion at buyer's expense or provide transportation charges prepaid. Champion's sole obligation under its warranty shall be, at its option, to repair, replace or refund the price of any product thereof which is proved to violate such warranty. In no event shall Champion be liable to the buyer for special, indirect, incidental or consequential damages whatsoever including, without limitation, loss of profit or revenue. Title and risk of loss have passed to the original purchaser upon delivery to a common carrier. If any product is damaged in transit, the original purchaser must file a claim with the carrier, which claim is not a warranty claim. If you have any questions regarding your warranty please contact our sales department at 1-866-391-4200.